

ERFA

CIVIL AVIATION





ABOUT US

We serve to our customers in machining and metal cold processing sectors such as mainly civil aviation MRO, defence industry, automotove industry, renewable energy, energy transporting lines, automation systems, special machinery manufacturing.

PLATFORMS

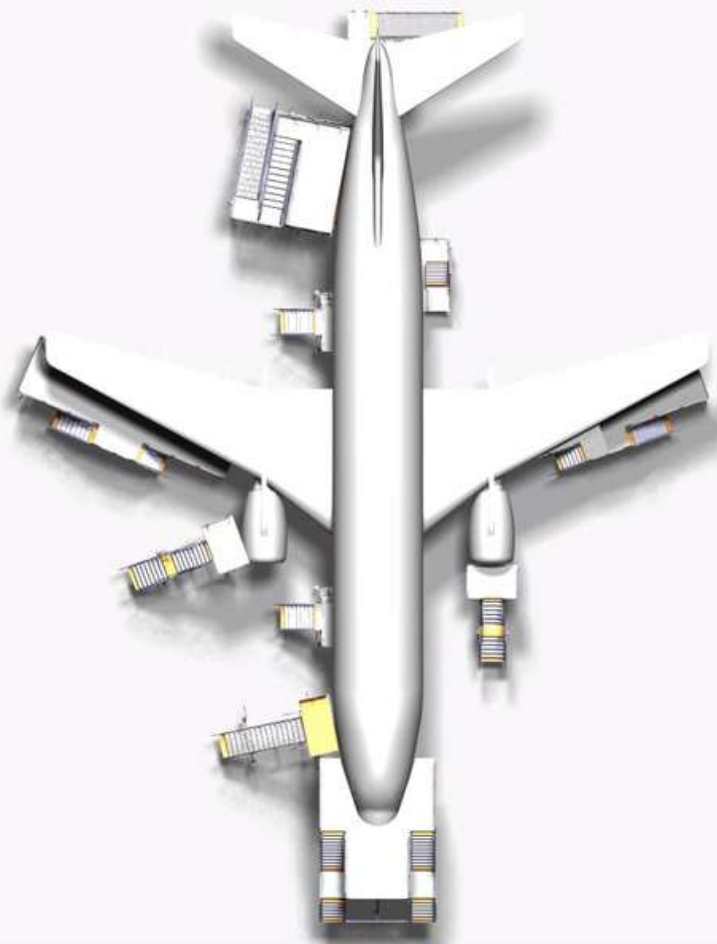
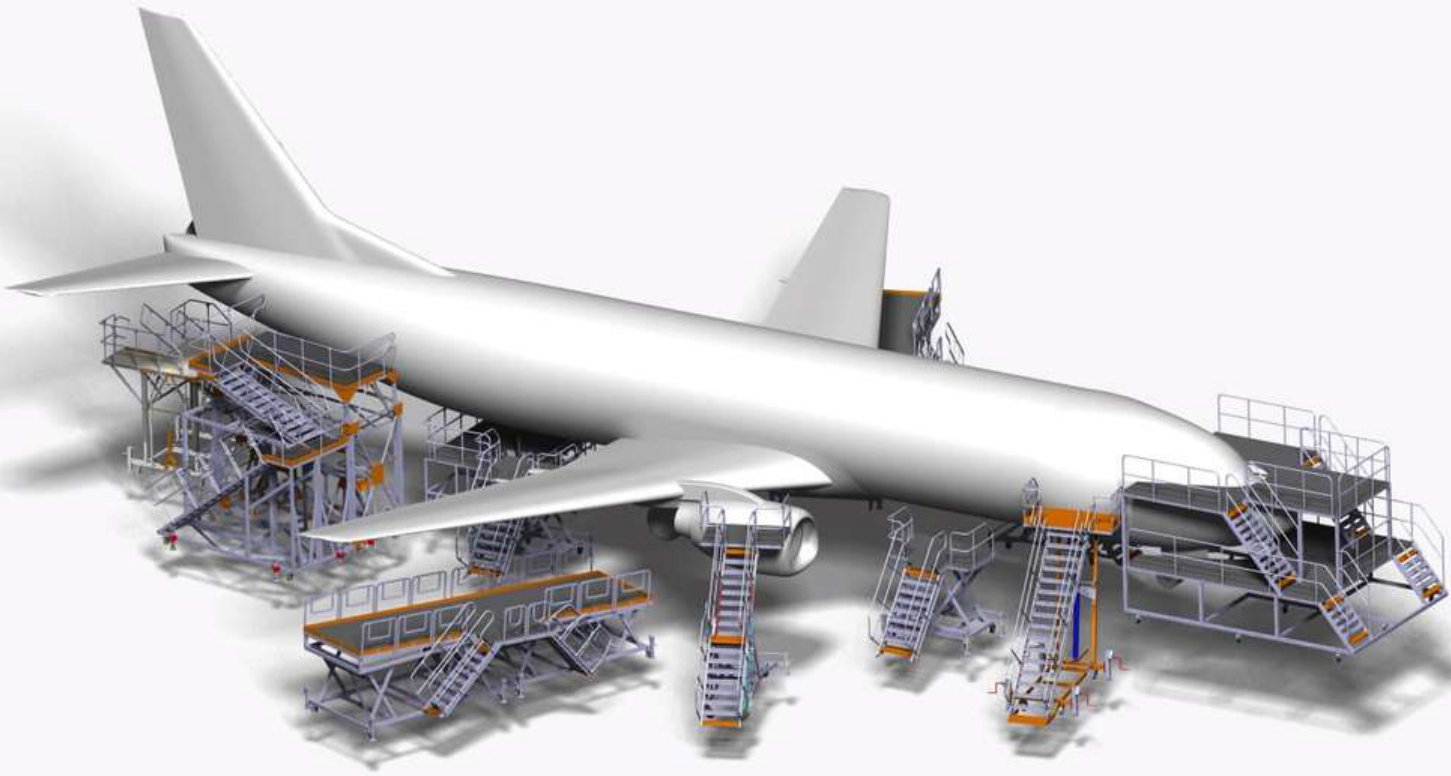

APU STAND

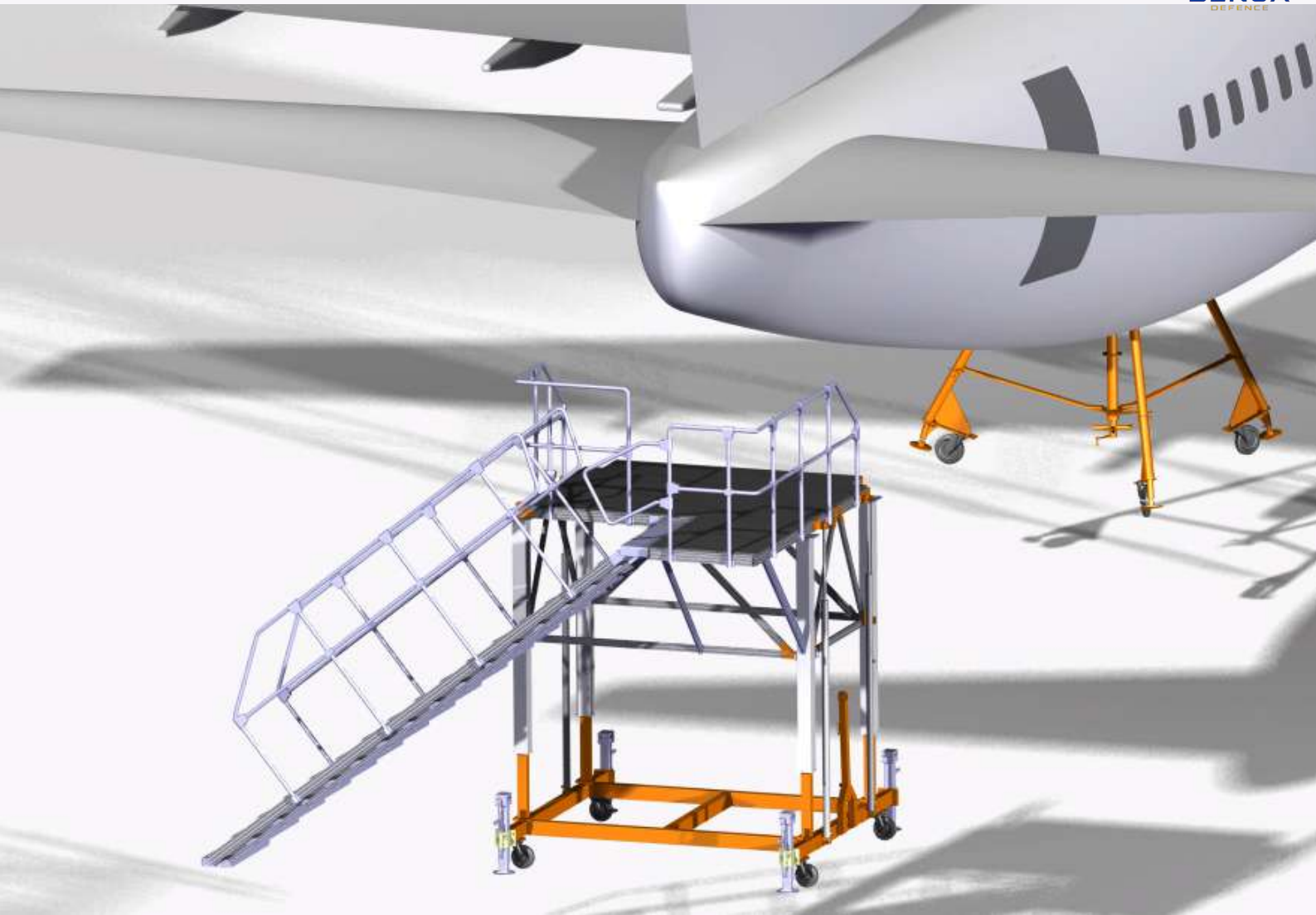

Technical Specifications

- **APU Maintenance Stand is a platform we have developed to remove and do maintenance work on the APU of the plane.**
- **APU maintenance stand requires minimum number of technicians to operate.**
- **Height adjustment can be optionally controlled by hydraulic or electric pistons.**
- **Due to its rigid structure it provides a vibration-free and safe working environment.**
- **The platform can easily be fixed to the working area with its adjustable gearbox jack.**
- **The contact points to the aircraft is protected by special bumpers of our own design.**
- **You can contact us for your needs of APU Maintenance Stands for different types of aircraft.**

 **Aircraft Applications : A320, A330**

CODE: EM088-000-000

PAX DOOR STAND

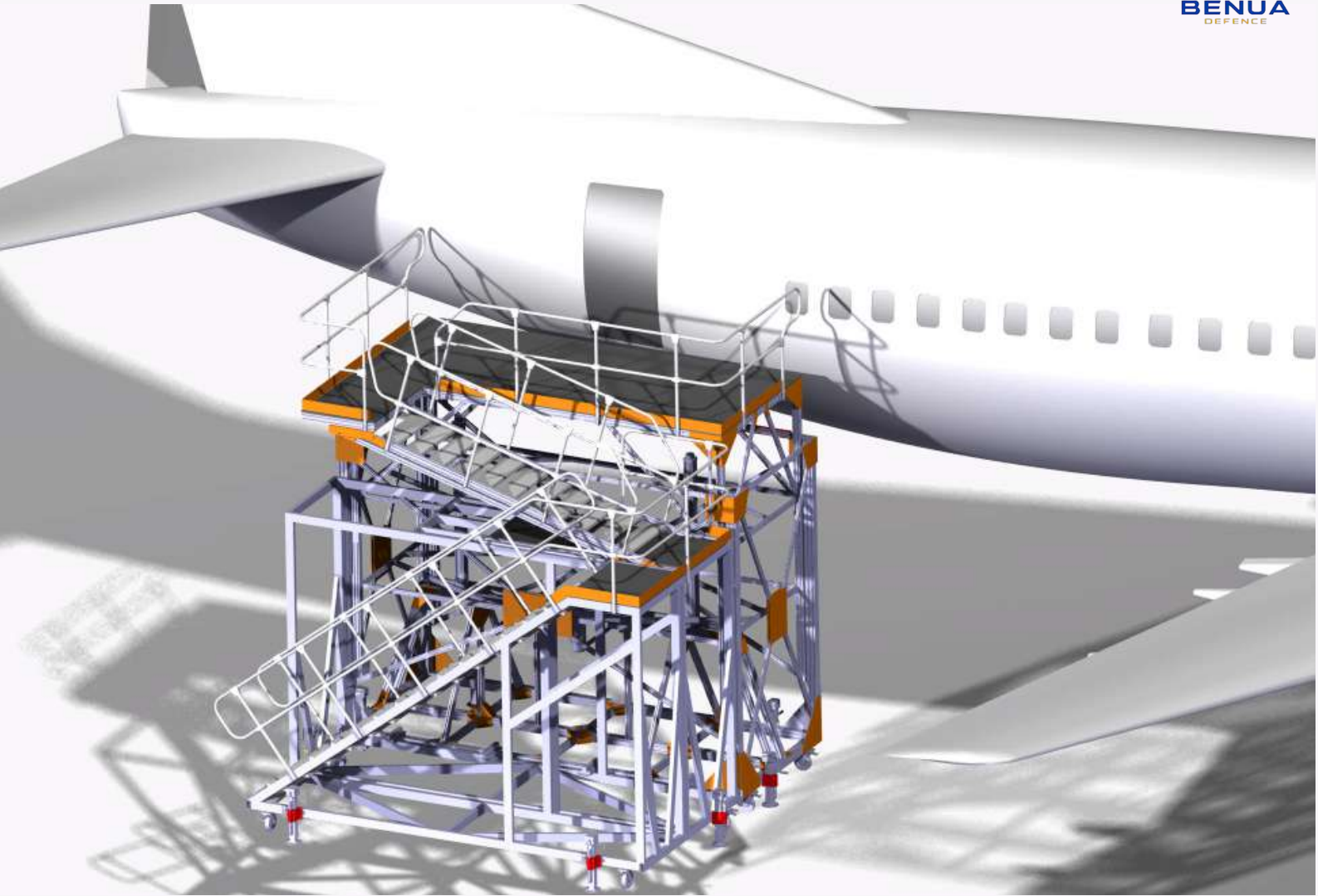

Technical Specifications

- **PAX Door Stand is a maintenance and repair platform designed to be used on different aircraft types.**
- **It provides an easy-to-work area with its maximum 6300mm ascending height and wide working environment.**
- **Its ascending mobility is provided by an electric piston and it's supported by a rechargeable battery.**
- **The platform can easily be fixed to the working area with its adjustable gearbox jack.**
- **The contact points to the aircraft is protected by special bumpers of our own design.**
- **You can contact us for your needs of PAX Door Stands for different aircraft types.**



Aircraft Applications : B787, B777, A330, A340

CODE: EM046-000-000

CARGO STAND

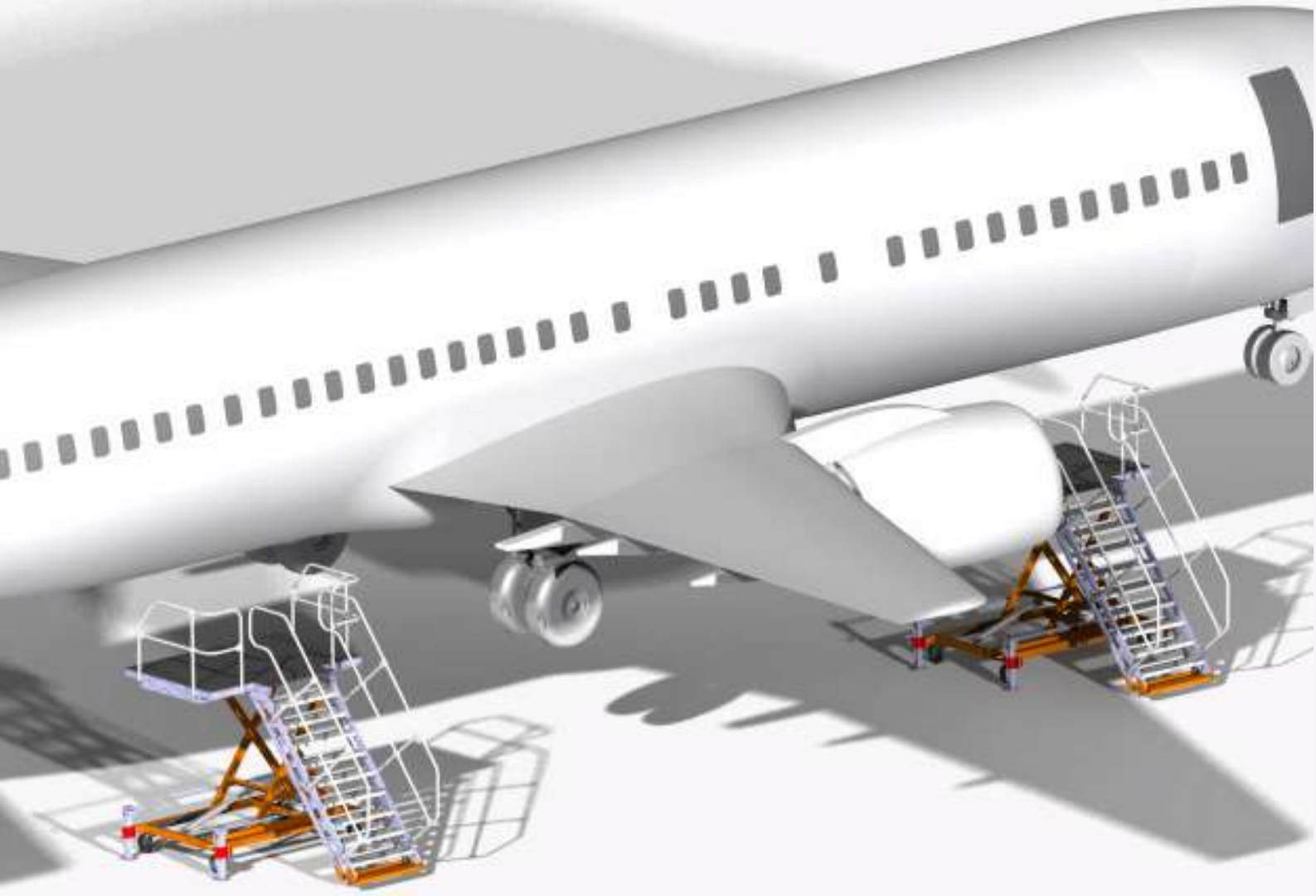

Technical Specifications

- **Designed for accessing FWD and AFT cargo doors, it provides easy and hassle-free access to those doors for maintenance and repair.**
- **It has a scissor mechanism and is supported by hydraulic cylinders.**
- **The platform can easily be fixed to the working area with its adjustable gearbox jack.**
- **The contact points to the aircraft is protected by special bumpers of our own design.**
- **You can contact us for your needs of Cargo Stands for different aircraft types.**



Aircraft Applications: A320, B737

CODE: EM089-000-000

UNDER WING ACCESS STANDS



Technical Specifications

- Under Wing Access Stand is designed to provide the most suitable and ergonomic working conditions under the wings of the aircraft.
- The ascending height is adjusted by hydraulic cylinders.
- The height can be adjusted so that the aircraft can be worked on while it's on the wheels or on the jack.
- It can be easily relocated due to its aluminum structure and heavy-duty wheels.
- Optionally the railings can be opened and closed.
- The platform can easily be fixed to the working area with its adjustable gearbox jack.
- The contact points to the aircraft is protected by special bumpers of our own design.
- You can contact us for your needs of Under Wing Access Stand for different aircraft types.



Aircraft Applications: A330, B777

CODE: EM090-000-000

PYLON STAND



Technical Specifications

- This platform is designed to access the Pylon area in different aircraft types.
- Due to its aluminum structure, it provides an easy use to the operator.
- With its lightness and high capacity, it also can be used on different parts of the aircraft during maintenance.
- The platform can easily be fixed to the working area with its adjustable gearbox jack.
- The contact points to the aircraft is protected by special bumpers of our own design.
- You can contact us for your needs of Pylon Stands for different aircraft types.



Aircraft Applications: A320, B737

CODE: EM047-000-000

ENGINE ACCESS STAND

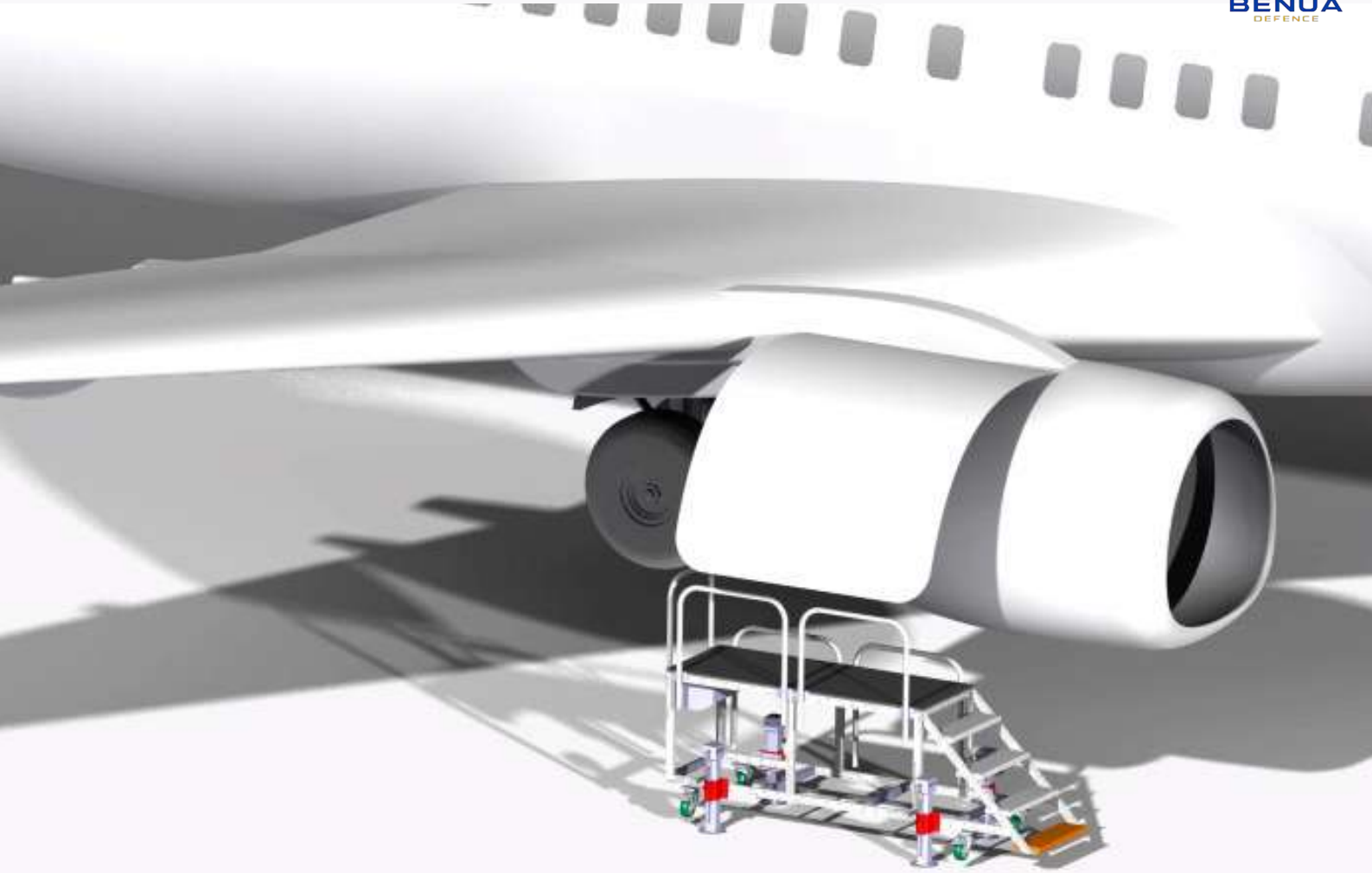

Technical Specifications

- It is designed to provide an easy-to-work environment for technicians in the engine area where working environment is limited.
- The platform allows for 2 technicians to work together on the engine.
- The platform can easily be fixed to the working area with its adjustable gearbox jack.
- The contact points to the aircraft is protected by special bumpers of our own design.
- You can contact us for your needs of Engine Access Stands for different aircraft types.



Aircraft Applications: A320, A330, A350, B777, B787

CODE: EM091-000-000

PASSENGER DOOR STAND



Technical Specifications

- It is designed to provide access to the passenger doors of narrow and wide body aircrafts.
- Due its aluminum and steel structured it provides a rigid working environment.
- The height adjustment is controlled by a hydraulic cylinder and extra safety is added with its safety lock.
- The platform can easily be fixed to the working area with its adjustable gearbox jack.
- The contact points to the aircraft is protected by special bumpers of our own design.
- You can contact us for your needs of Passenger Door Stands for different aircraft types.



Aircraft Applications: B737, A320

CODE: EM085-000-000

COCKPIT WINDOW AREA ACCESS STAND



Technical Specifications

- It is designed to provide access to the windows of the aircraft cockpit.
- It can easily be relocated due to its aluminum structure and heavy duty wheels.
- The platform can easily be fixed to the working area with its adjustable gearbox jack.
- The contact points to the aircraft is protected by special bumpers of our own design.
- You can contact us for your needs of Cockpit Window Area Access Stands for different aircraft types.



Aircraft Applications: B737, A320

CODE: EM092-000-000



MLG-NLG REMOVAL DOLLY

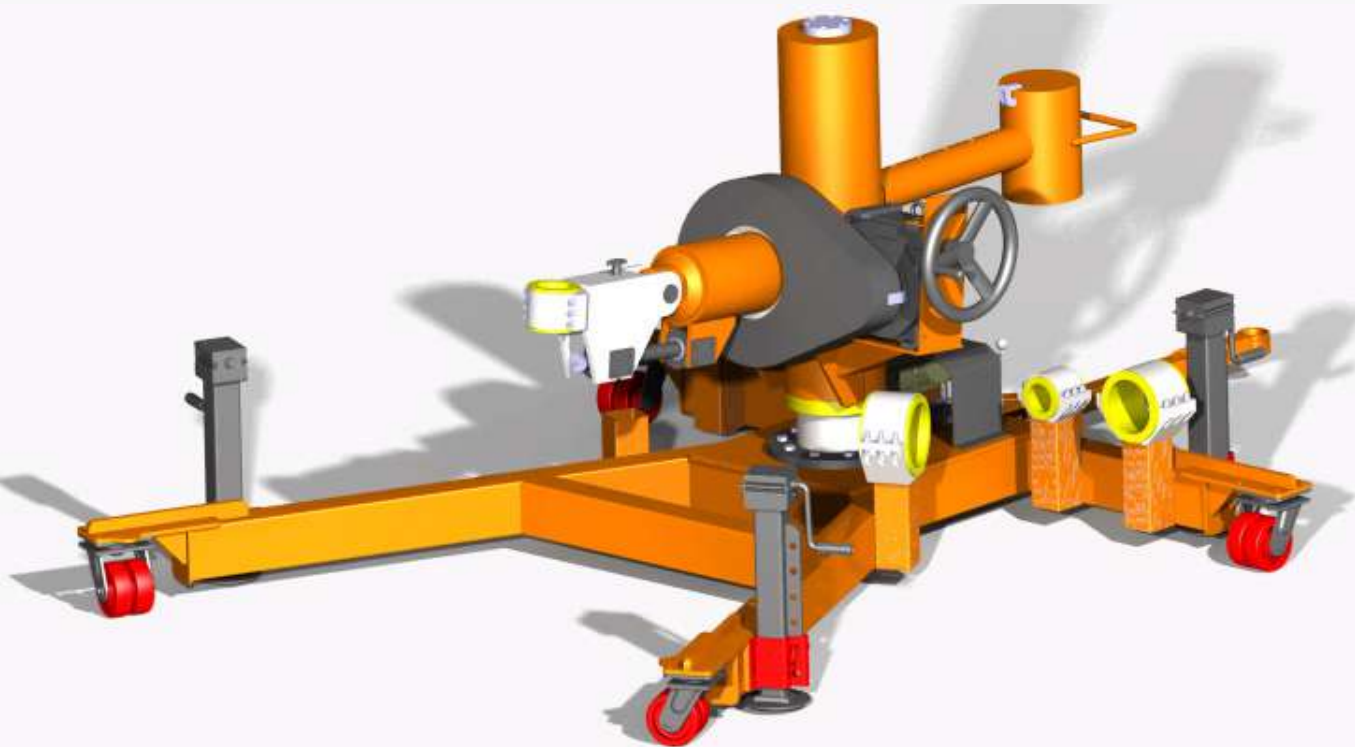

Technical Specifications

- Total Lifting : 750 mm
- Load Capacity : 1500 Kg
- It can be turn around itself about 360 °
- Clamp can be turn 45 ° left and right.
- Working Pressure : 6 bar
- It has hyraulic piston, hydropneumatic piston, 2 reductor



Aircraft Aplications:

CODE: EM041-000-000

A320, A330, A340,B737

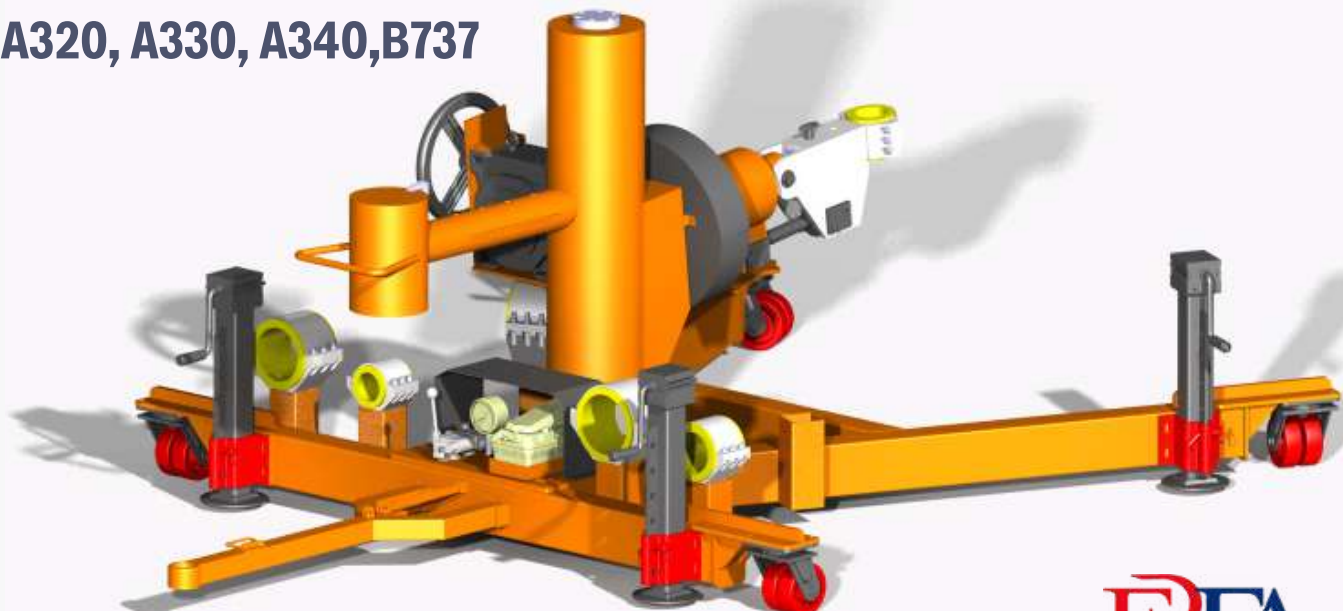

A340 MLG STAND

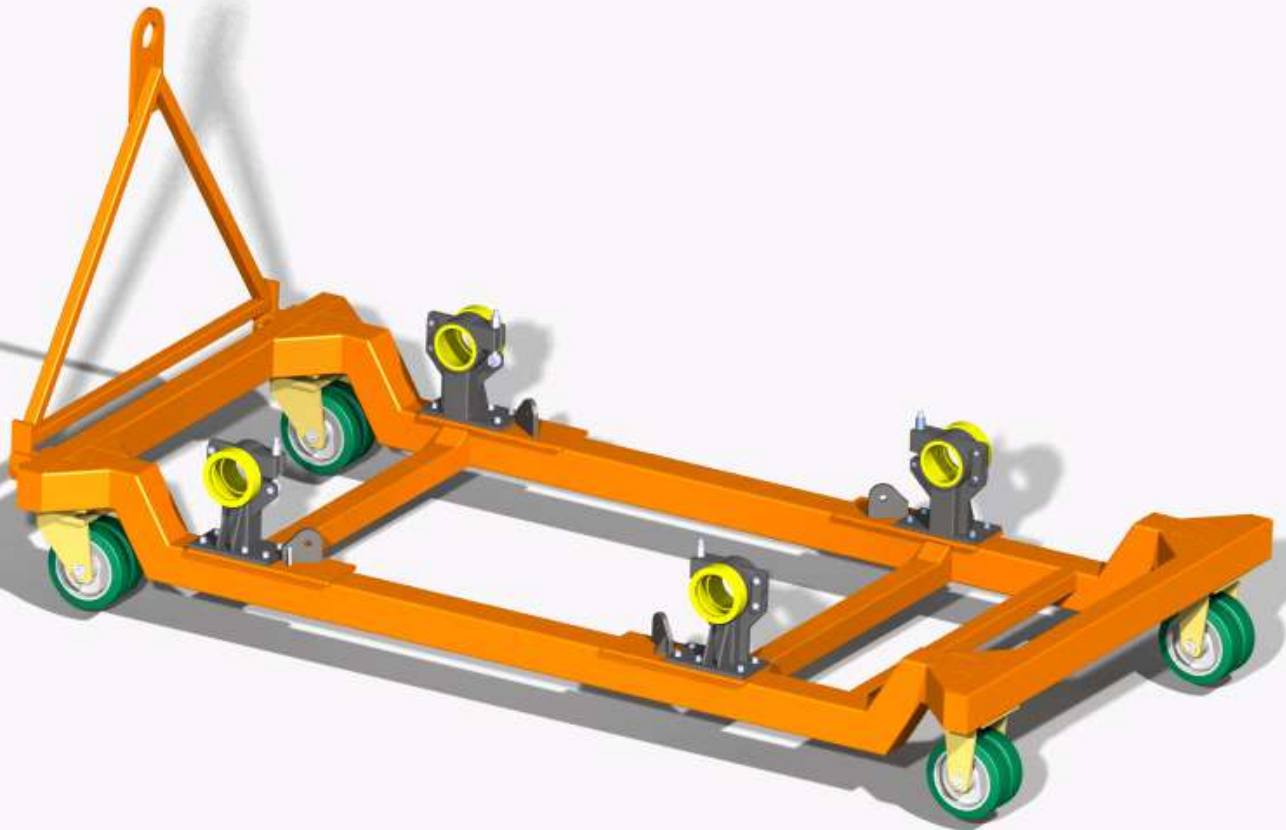

Technical Specifications

- It is designed to safely carry the rear landing gear of the aircraft.
- Made of steel.

CODE: EM097-000-000

NLG STAND



Technical Specifications

- It is designed to safely carry the front landing gear of the aircraft.
- It has a steel structure and movement is provided by a hydraulic piston.

CODE: EM098-000-000

FAN BLADE

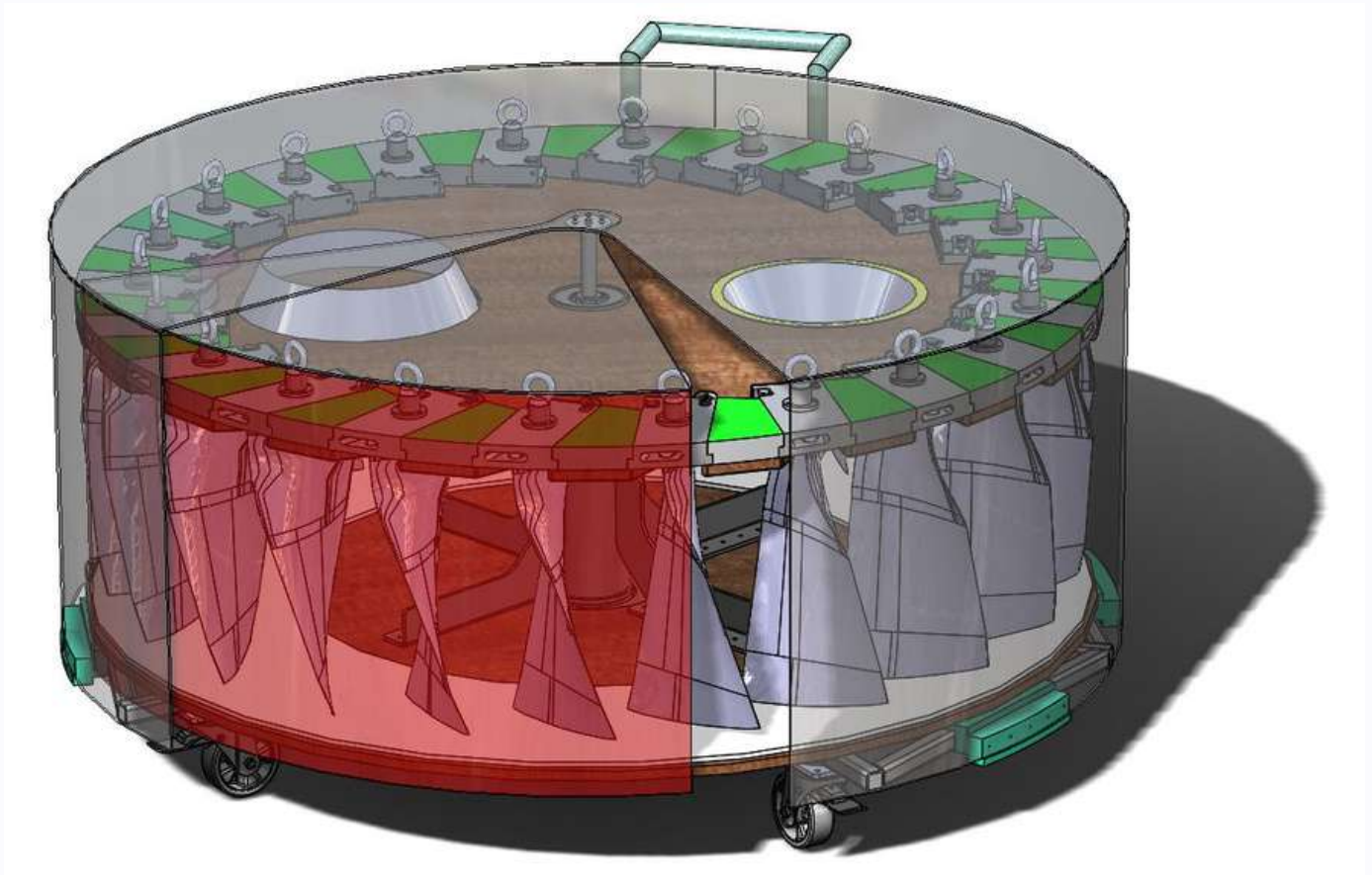

Technical Specifications

- The V2500 is designed to carry fan blades.
- With its mating arrangement , it facilities the control over materials and allows user to easily notice missing parts.
- Easy to transport and high maneuverability due to fast mechanical connection system.
- With blade distances, there is no possibility of contact between the blades.
- Fastening pins and three-axis locking mechanism ensure that the blades are fixed.

CODE: EM078-000-000

SCREW JACK

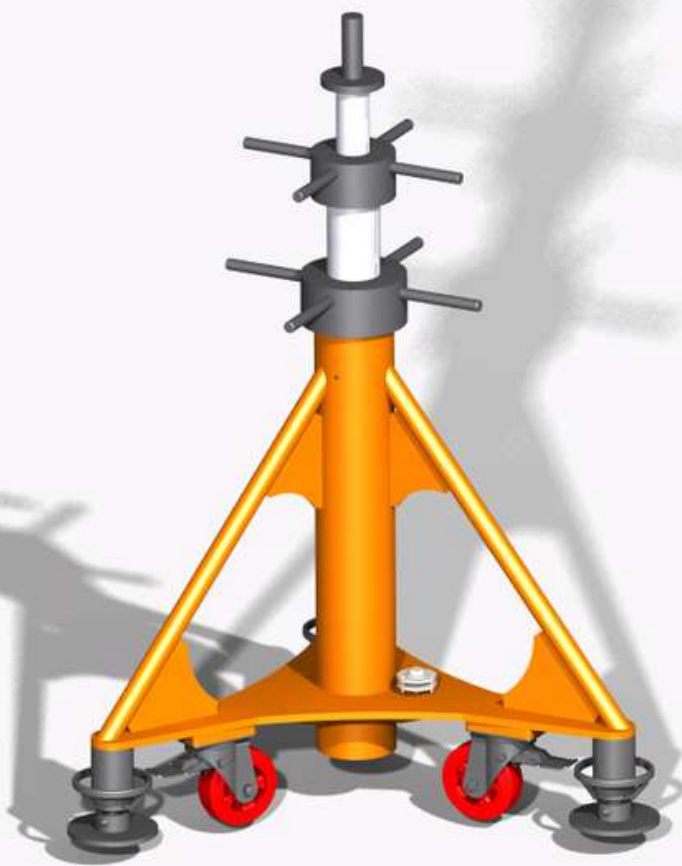

Technical Specifications

- Total Weight : 250 kg
- Dimensions : 1110 x 1100 x 1200 [mm]
- Max. Loading Capacity : 100 kN
- Total Lifting Height : 1340 mm

It's used for lifting and supporting airplanes at maintenance processes.

CODE: EM058-000-000



Technical Specifications

- **The tool is designed for testing Screw Jacks of different capacities.**
- **There are two models as hydraulic and loadcell.**
- **Test capacity : 160,000 kg**

CODE: EM093-000-000

WHEEL AND BRAKE CHANGE DOLLY



Technical Specifications

- Adjustable wheel lifting arms 230mm to 974 mm
- Lifting arm width 650 mm
- Nominal Capacity: 350 kg
- Mechanism : Hydraulic piston
- 4 swivel casters



Aircraft Applications :
A300, A310, A320, A330, A340
CODE: EM042-000-000

WEIGHT TRANSPORT CART



Technical Specifications

- **Loading Capacity : 4 tones**
- **Capacity : 5 ramp wedges , 17 intermediate steps , 14 weighing devices, 6 ramps**
- **Max. velocity limit : 5 km/h**
- **Input : 100– 120 VAC 7 A**
- **Output: 14,4 V – 24,3 A**

CODE: EM034-000-000

START AIR ADAPTER



Technical Specifications

- Total Weight : 285 kg
- Dimensions : 2420x908x1500 [mm]
- Inlet Pressure : 7 bar
- Max. Pressure Difference : 2 bar

An air-start system is a power source used to provide the initial rotation to start aircraft engines.

CODE: EM056-000-000

NITROGEN SERVICE CART -1



Technical Specifications

- It has the capacity to carry 1 nitrogen tube.
- It has high maneuverability.
- Provides ease of use.

CODE: EM063-000-000

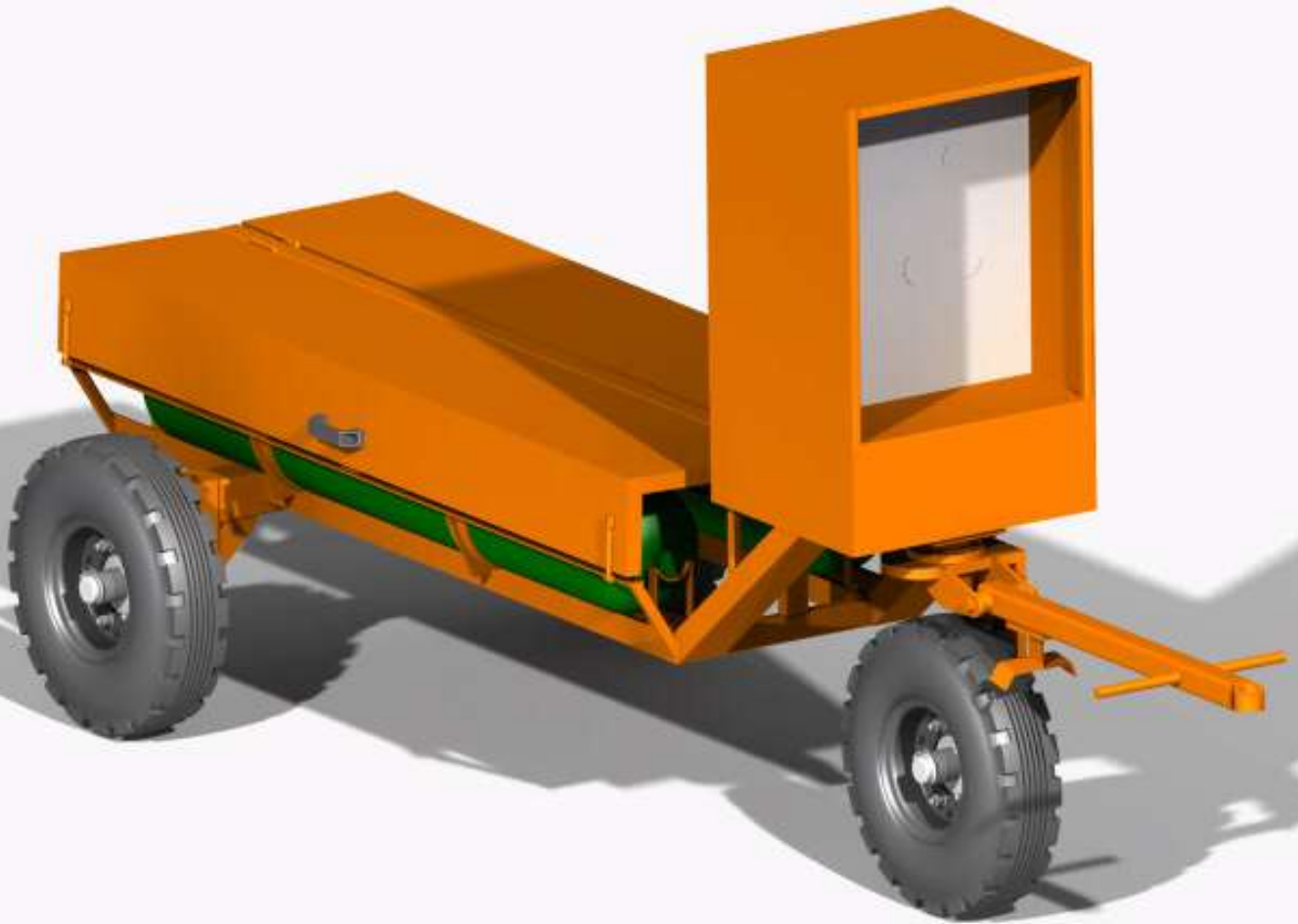

Technical Specifications

- It has the capacity to carry 2 nitrogen tubes.
- It has high maneuverability.
- There are pressure gauges.
- The cart has a tow bar so that it can be moved with the vehicle.
- Provides ease of use.

CODE: EM033-000-000

RADOME TROLLEY

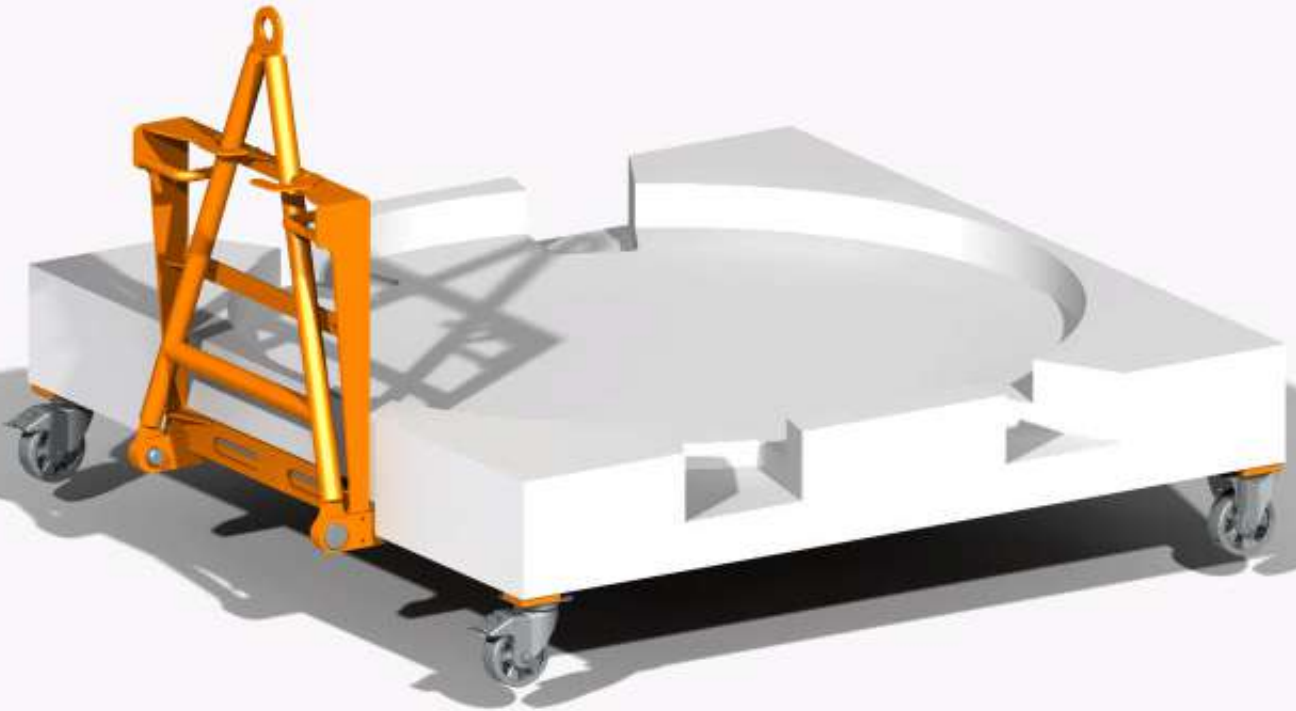

Technical Specifications

- **Loading Capacity : 250 kg**
- **Dimensions : 1920 x 1850 mm**



Aircraft Applications : A320

CODE: EM062-000-000

FAN COWL TRANSPORT

TROLLEY

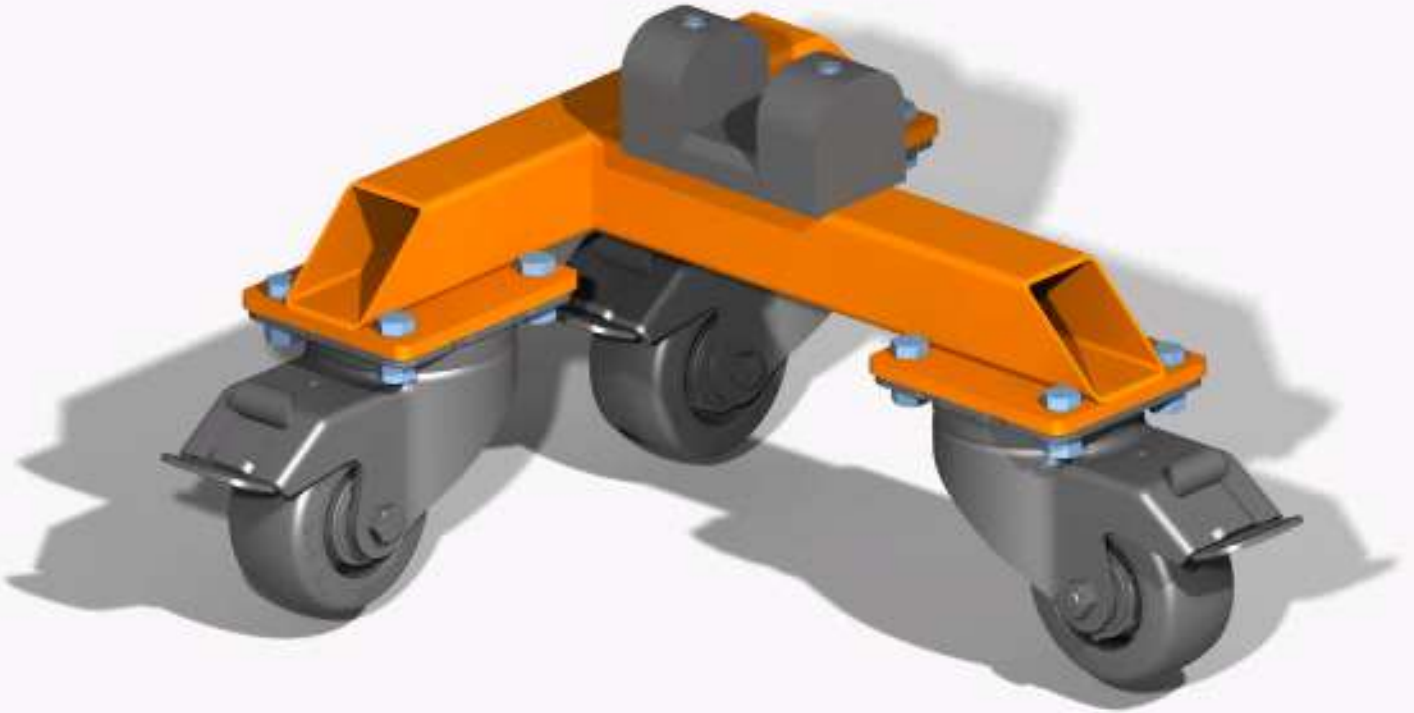

Technical Specifications

- It is designed for the transport of fan cowls that close the aircraft engine from the right and left.
- Surface that does not damage the fan covers due to it provides a safe use.

CODE: EM001-000-000

THRUST REVERSER

TROLLEY

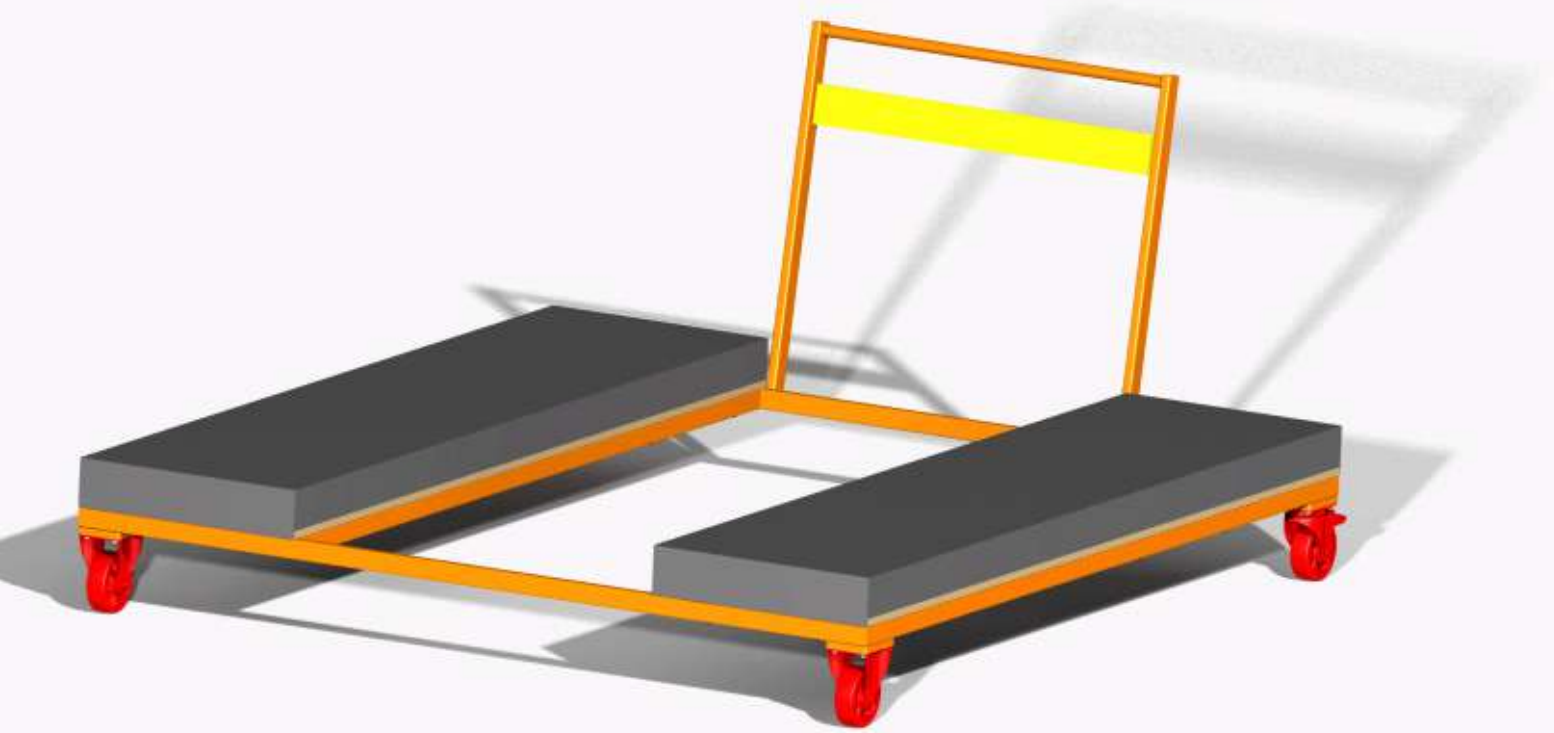

Technical Specifications

- It is designed to carry the reverser part of the engine and the contact surfaces are coated in a way that will not damage the product.
- It consists of steel structure.

CODE: EM002-000-000

AIRCRAFT WHEEL AND BRAKE CHANGE TRAILLER

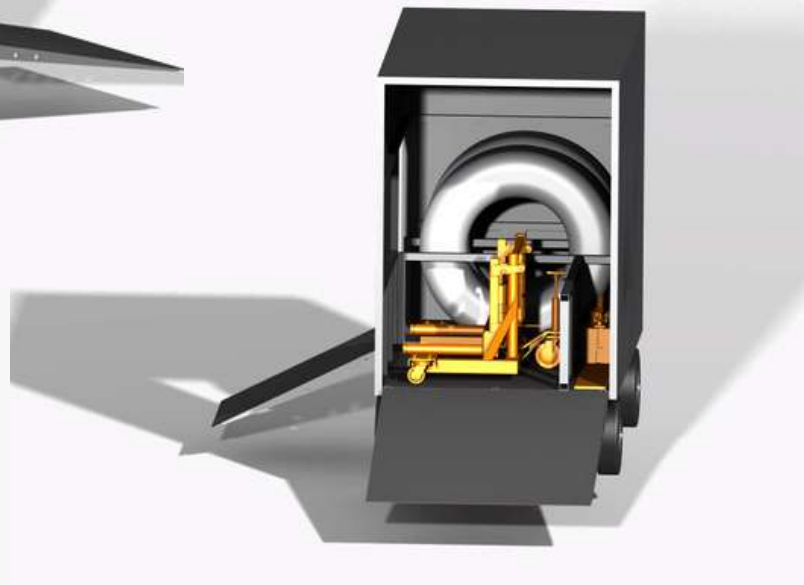
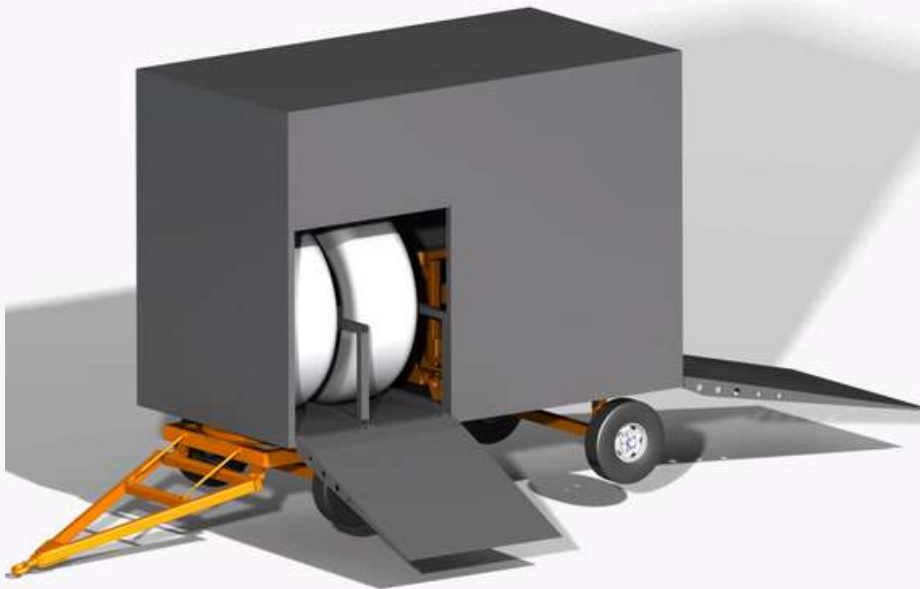

Technical Specifications

- It is designed for transporting aircraft wheel, hydraulic jack and wheel transport trolley at one time.
- It is completely in the structure of a trailer and all its surfaces are closed.
- Made of steel.

CODE: EM094-000-000

BAGGAGE CART



Technical Specifications

- It is designed to carry 1500kg of baggage.
- It works with the same mechanism as a trailer.
- The side railings can be opened and closed.
- It has a braking system for when it is parked.

CODE: EM095-000-000

SHEET METAL STORAGE UNIT



Technical Specifications

- It is designed for stacking sheets of metal of different sizes in a smaller space.
- It provides easy due to its rolling shelves.

CODE: EM054-000-000

SEAT TROLLEY

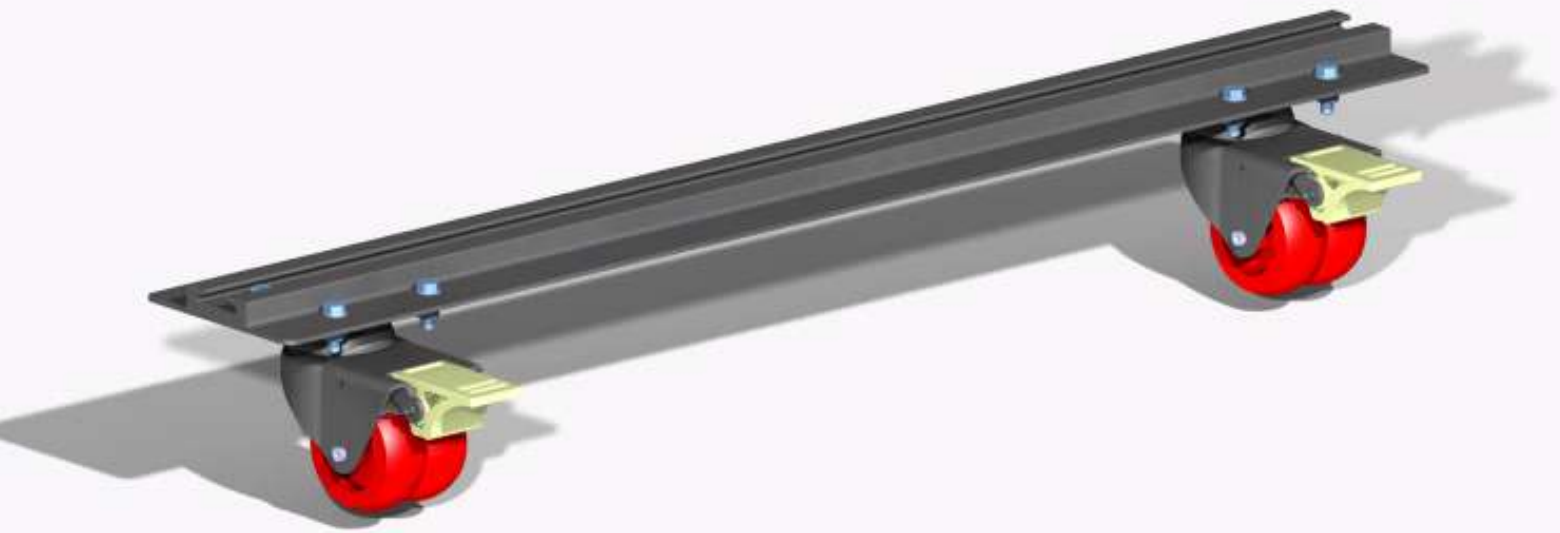

Technical Specifications

- **Designed to safely transport aircraft seats.**

CODE: EM008-000-000

RIM LIFTING TOOL

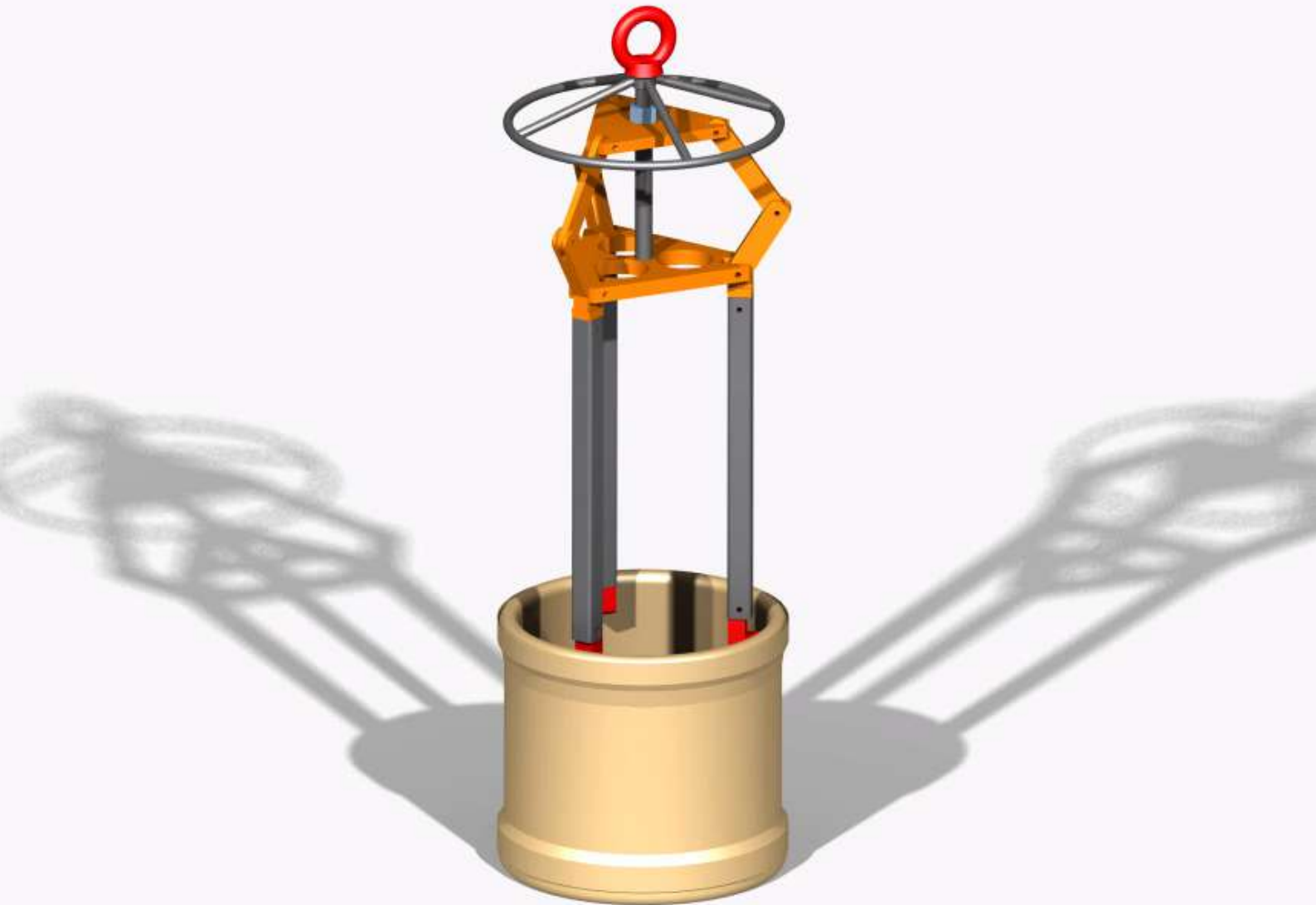

Technical Specifications

- It is designed to lift and transport different types of aircraft rims.

CODE: EM096-000-000

BOOTSTRAP SYSTEM DOLLY

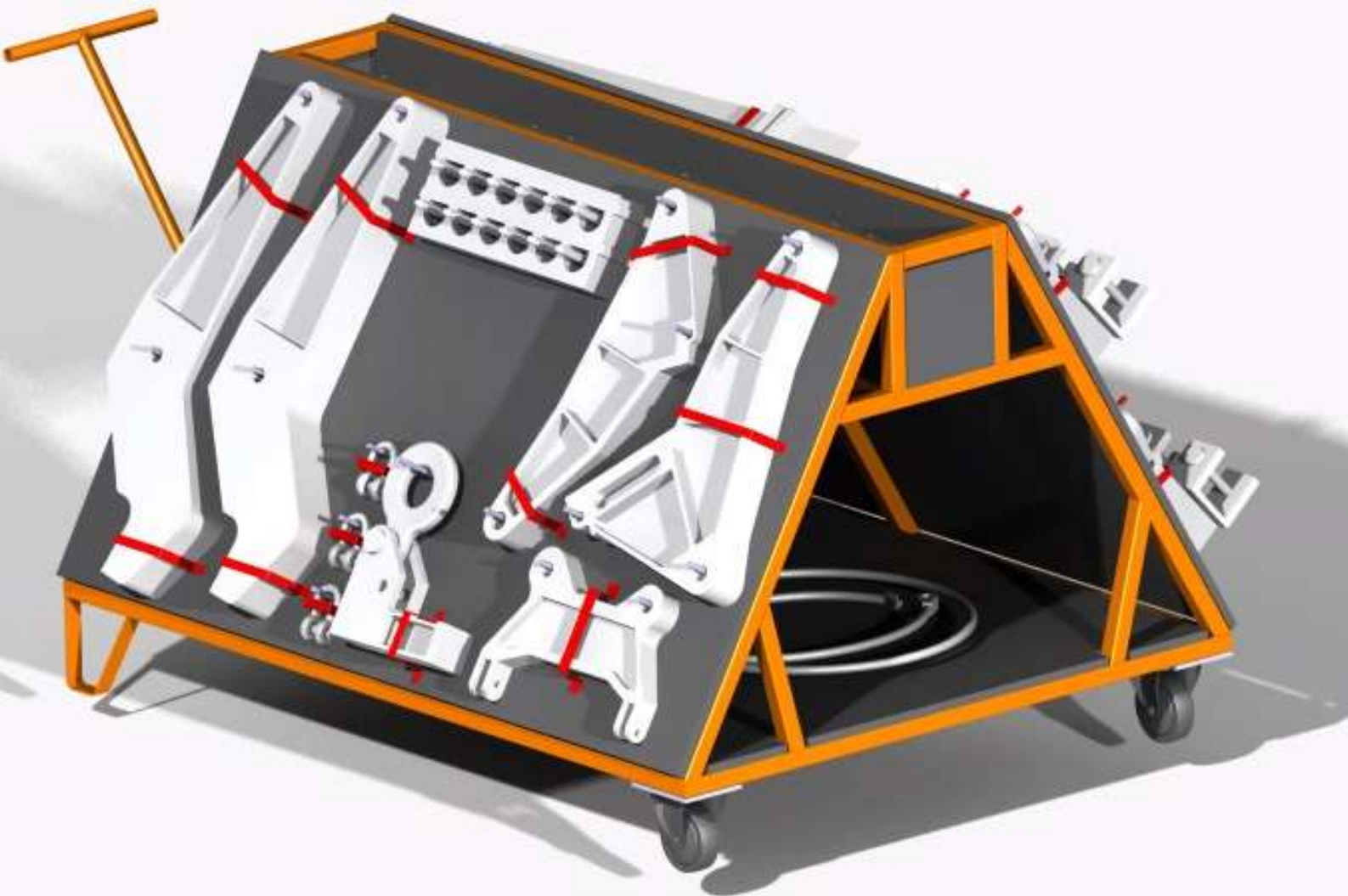

Technical Specifications

- It is designed for bootstrap equipments used on B777 airplanes equipped with GE90 engines.



Aircraft Applications : B777

CODE: EM050-000-000

WIRE FENCE



Technical Specifications

- Designed to surround work areas.
- It is manufactured in different sizes.

CODE: EM055-000-000

3 STEPS INTERIOR STAND



Technical Specifications

- **Designed for in-cab maintenance use.**
- **It is made of aluminum and has an ergonomic use.**

CODE: EM057-000-000

2 STEPS INTERIOR STAND



Technical Specifications

- **Designed for in-cab maintenance use.**
- **It is made of aluminum and has an ergonomic use.**

CODE: EM070-000-000

ARINC BOX



- **As ERFA, we offer innovative solutions to our customers and help them get better results and higher profits by doing original and tailor-made designs.**
- **We give services in Solid Modelling (3D CAD Model) and production, production via CAM programming, product development processes, maintenance and repair, assembly, deassembly, new part production, painting and coating, NDT and certification of produced products.**

ABRASIVES AND PROTECTORS

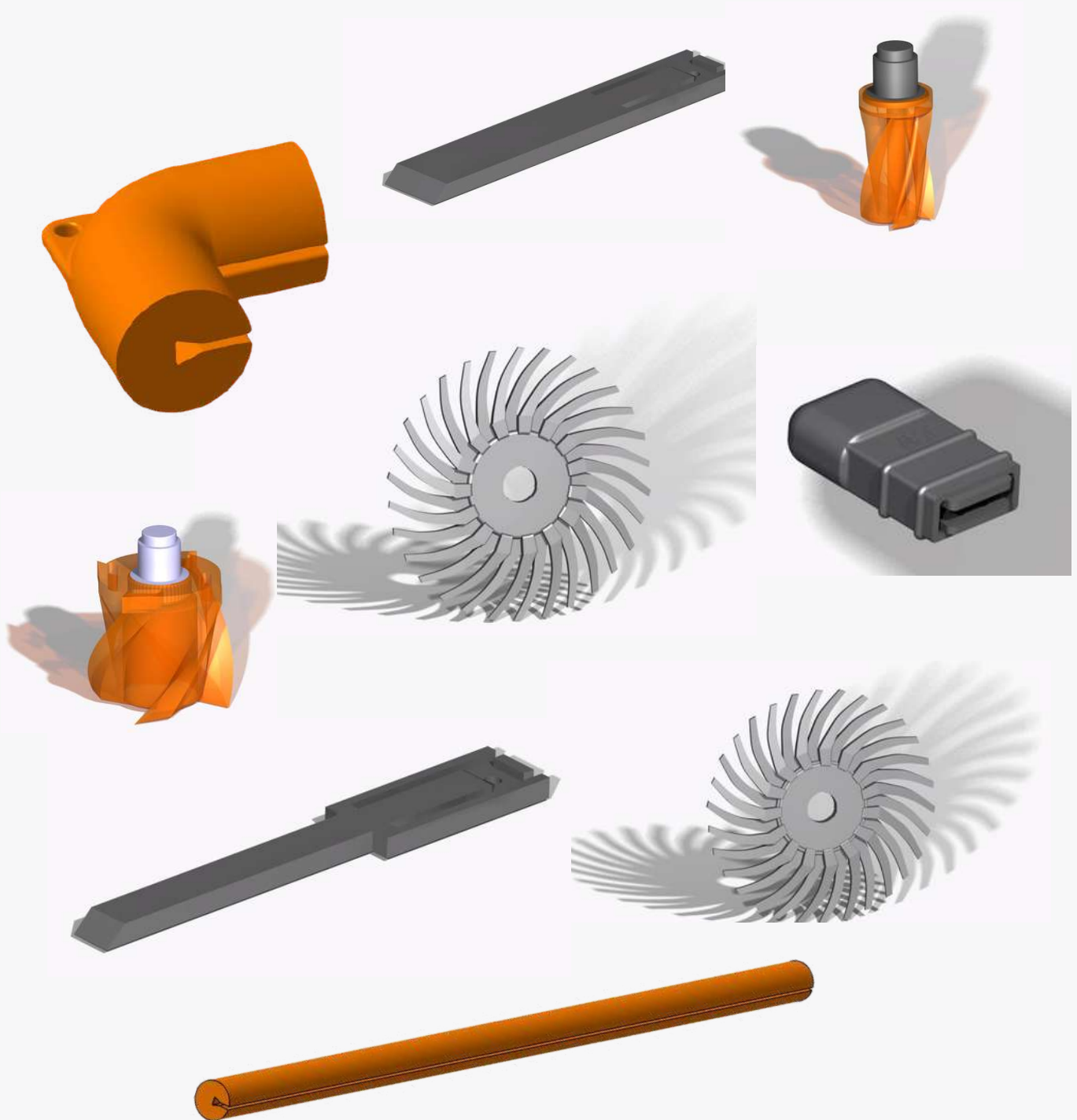

SCRAPER

PCUT001 / PCUT002

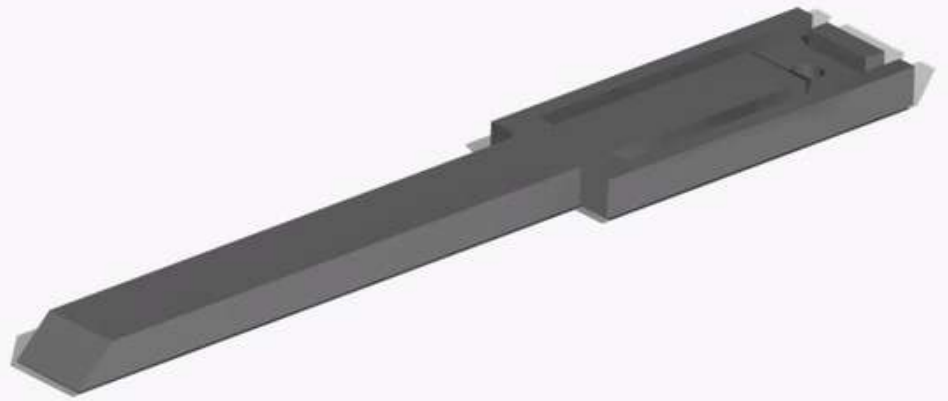
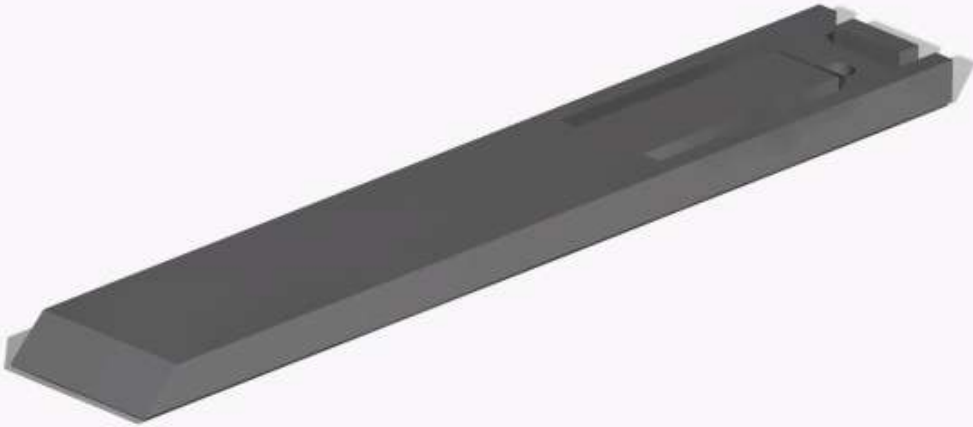

Technical Specifications

- Produced from thermoplastic.
- Resistant to hot water, hydrocarbons and solvents.
- Suitable for sealant actions, delacquering and other abrasive actions.
- Comes in two different sizes.

CODE: ES-009 (PCUT001)

CODE: ES-010 (PCUT002)

SCRAPER HANDLE



Technical Specifications

- This product is designed for the technician to use scrapers more ergonomically .

CODE: ES-015

STRUCTURAL MILLING CUTTER

0,8" / 0,4"



Technical Specifications

- Produced from polyetherimide, it's used to clean sealant components and coatings without damaging the paint, the linings or the metal on the lower levels.
- It's used only by attaching to rotary devices.
- It comes in two different sizes.

CODE: ES-011 (0,8")

CODE: ES-012 (0,4")

RADIAL DISC

3" / 2"

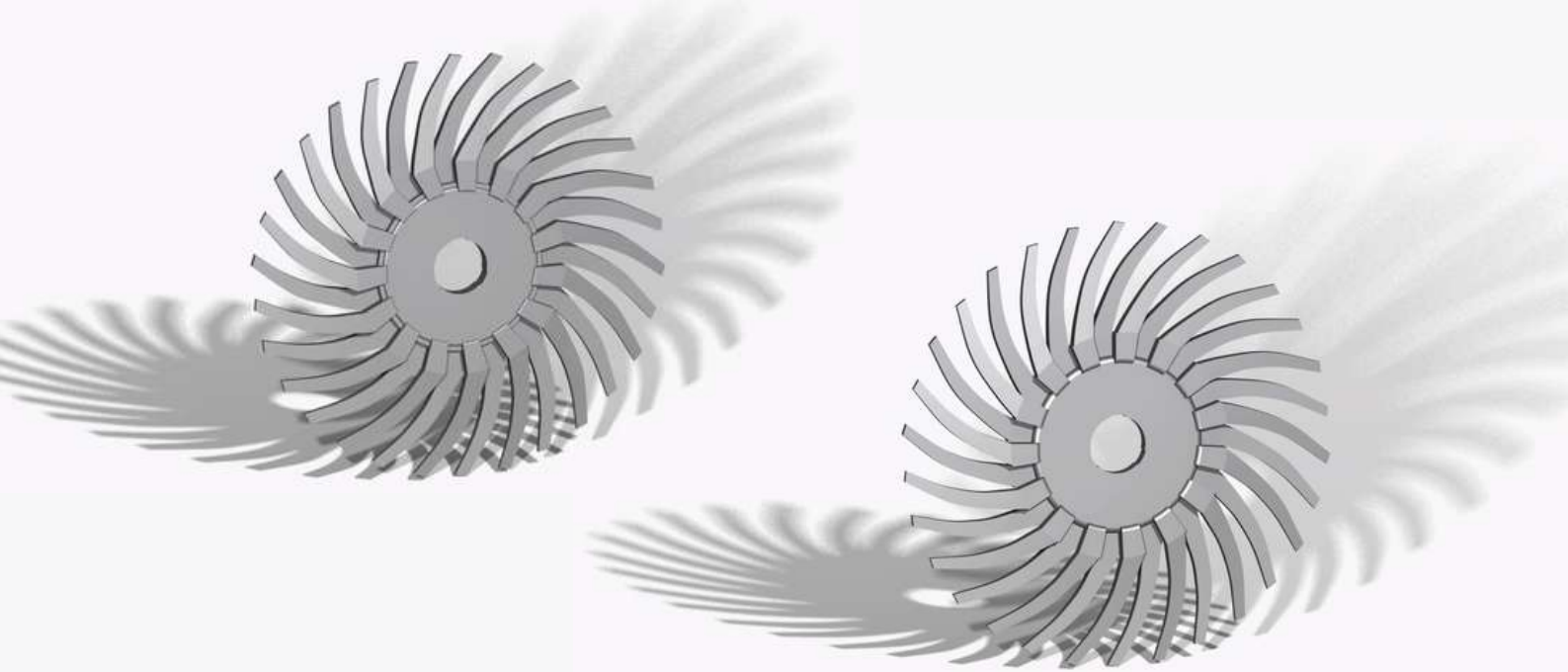

Technical Specifications

- Due to its protruding shape, it is used to remove filler, silicon, RTV and adhesive layers without stripping the paint or the coating.
- It comes in two different sizes.

CODE: ES-013 (2")

CODE: ES-014(3")

BUMPER

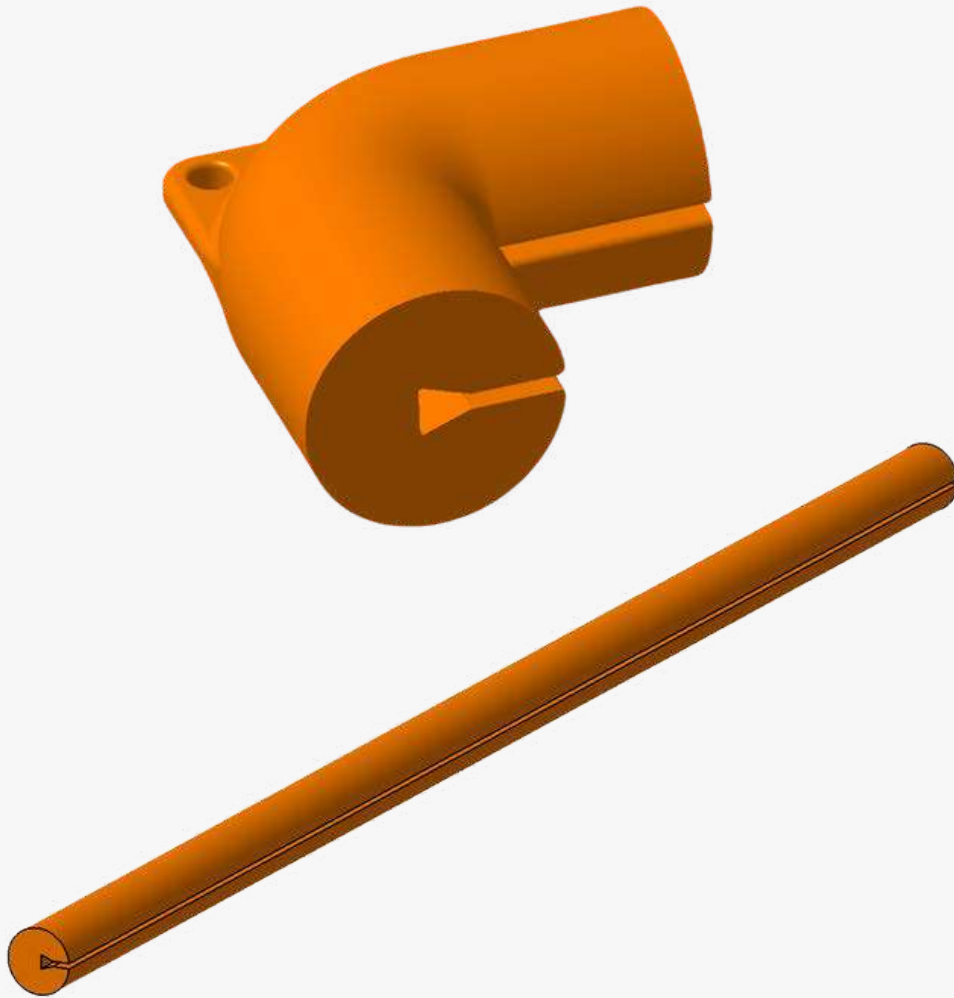

Technical Specifications

- It is designed to cover sharp corners on platforms and surfaces that may contact the aircraft.
- There are two types of bumpers ; one for the corner and one for the sides.

CODE: ES-016 (90°)

CODE: ES-017(180°)



REFERENCES



SunExpress



AMAC AEROSPACE



ERFA TORNA MAKİNA SAN. ve TİC. LTD. ŞTİ



www.erfamakina.com.tr



+90 224 441 48 20



erfa@erfamakina.com.tr



Demirci Mahallesi, Deligönül Sk. No: 7, 16130 Nilüfer/BURSA

